



Club By-Laws of the Southern Districts Car Club of SA

(Updated February 2022)

Can only be changed with the approval of the **General Committee**

Contents

- 1. Office Bearer Positions**
- 2. Club Champion Eligible events and point scoring structure**
- 3. Khanacross Series – Outright and Class points structure**
- 4. SDCC Khanacross Rules**
- 5. Membership Types, Entitlements & Fees**
- 6. Sub Committee establishment/dissolution**

1. Office Bearer Positions

In addition to the Executive, Members are eligible to nominate for the following office bearer positions and will form the General Committee, Multiple positions may be held by the same person.

Membership Secretary

Editor

Equipment officer

Public Relations & Promotion

Public Officer (currently the role of the Club Secretary)

JDP co-ordinator

Website

Social Media Admin

Social & Fundraising

Canteen Manager

Auditor

Motorsport Australia SA Rally Panel Delegate

Motorsport Australia SA Autotest Panel Delegate

MMM Park sub-committee Chairperson

Seal Holder

2. Club Champion Eligible events and point scoring structure

The principle of the SDCC Club Champion award is to acknowledge excellence and encourage participation in Motorsport Australia (MA) run events in SA. The award can be weighted to suit the circumstances of the clubs competition base.

In years that SDCC events struggle to find enough entrants to make our events viable, inclusion or more weighting can be placed on SDCC run events to encourage commitment.

In years where our competitor base is strong, more weighting can be placed on encouraging Members to excel in their chosen discipline and non-SDCC MA run events that form part of a State or National level event, series or championship can be included, if it represents events that SDCC Members enter in numbers.

A balance should be sought to reward Members that enter SDCC events and to recognise those who have competed in higher level events run in South Australia.

Therefore, the selection of events will differ from year to year and the method for acknowledging this will change to suit the events that are on offer and also to reflect the demographic of the Members and which type of events they compete in.

It is also a desire to avoid one competitor running away with multiple competition trophies (eg Khanacross Series and Club Champion) by the design of the system, but still recognise exceptional performance and dominance if appropriate. Support of Members in a variety of disciplines, even if SDCC are not organisers of the particular discipline, is to be encouraged.

It is therefore the role of the incoming Committee to carefully consider the method of event selection to achieve the above goals. Reward commitment to SDCC events, acknowledge high achievers & encourage diversity.

Method for allocating points

- a. Once the events are determined, only SDCC Members who have a level of Membership that makes them eligible for Club Champion points are considered (refer table in Section 5). They need to be a Member at the time of commencing the event. There is not a requirement to list SDCC as their club if they are Members of multiple car clubs.
- b. The highest finishing Member will receive the maximum points regardless of finishing position in the entire field, the second highest finishing Member will receive the second highest number of points regardless of the overall finishing position.
- c. The exception to this rule is when they enter in the category more than once (eg they are a co-driver for 2 different drivers), For example, if they finish 1st and 2nd of SDCC Members, they will only get the highest of the 2 points for the event (not both) and the Club Member who finished 3rd, would become the second highest finishing club Member and receive the second highest finishing points.

- d. If they enter an event as a driver AND a co-driver, only their highest finishing club Member points go towards their Club Champion tally for that event. Their other positions still stand (except in the example of rule c above) and will still take up the position and allocate the points when calculating the position for subsequent SDCC finishers.
- e. Points for recognised tasks - The positions of Clerk of Course or Event Secretary allows a competitor to attract the maximum points for the event. If there is a coefficient or loading on some particular events over another, these do not apply – ie only the standard maximum points are issued (10 points). Points for Recognised tasks are only able to be granted a maximum of once per calendar year for the Club Champion award. (Does not prevent separate events being applied for across other competitions)

2022 Events – No loading applied to events this year (ie equal weighting)

Social Event

Economy Run – All participants receive 1 point

SDCC Khanacross Series (5 rounds TBC)

SA Khanacross Championship Series events (3 rounds TBC)

SDCC Multi-Club Autocross (1 event)

SA Autocross Series/Championship (3 rounds TBC)

Rallysprint

UME Rallysprint

SA Rally Championship Series events (4 rounds TBC)

Hillclimb

Willunga Hillclimb (UME)

Best 8 events count

Highest placed eligible SDCC Members - 10 points, 9, 8, 7, 6 etc

10th place onwards for being classified as a finisher – 1 point

DNF, DNS, Excluded – 0 points

Points for recognised tasks - Clerk of Course & Event Secretary (max 1 person per event) – 10 points (can only use once per year)

Additional or Replacement events may be added to the proposed list with approval from the General Committee (but cannot be done retrospectively)

3. Khanacross Series Outright and Class Points Structure

The principle and purpose of the SDCC Khanacross Series is to encourage competitors regardless of their budget or choice of vehicle (and subsequent class). There is a strong desire to incentivise people running what they have. Therefore, to award a person for their finishing position in their class, keeps them engaged and attracting SOME points, but still further rewards those who also have a high outright finishing position.

Historically, the winner of the Khanacross series has been a person who has shown a commitment to enter as many rounds as possible and been a consistent outright placed entrant.

Ladies Category – As recommended by the Australian Sports Commission, it has been encouraged that competitors are not given special awards on the basis of gender. This has been even further discouraged at higher level events eg State and National championship levels. Club engagement and feedback has shown that around half of our female participants like the opportunity to receive the ladies trophy at events. Therefore, for events, there is the opportunity to opt in or out to being considered for the event trophy. Once that decision is made to opt out, the competitor will also make themselves ineligible for the ladies points for the club series for that particular event.

Junior Categories – We have 2 categories for Juniors, ages 12-15 and 16-17. If a junior is under 16 at when they enter their first Khanacross for that calendar year, they can continue to accumulate points and be eligible for the 12-15 trophy for the remainder of that season. (In a similar way that other team sports treat their junior levels). It allows the competitor to start and finish in the same season and not split their points in the year that they turn 16. This however does not apply when they turn 18. Once they are over 18 (adults) they no longer can compete for the 16-17 trophy or points.

3.1 Awarding of Points in SDCC Khanacross Series – Eligibility

Only SDCC Members of the appropriate Membership level are eligible to score points in the Khanacross Championship. The Final results will 'discount' non-SDCC eligible members from the results, thereby moving subsequent SDCC Members up the outright and class finishing position list (for the purpose of points)

The roles of Clerk of Course and Event Secretary (unless rejected by the Member) shall attract full O/R points for the Outright Series, and full Class points for the class series. This can only be utilised once during the Khanacross series.

The Clerk of Course may nominate a class that they wish to receive full points for the determination of Class Series and/or category (J, J16 or L) points, but it must be in a class they have, or intend to enter during that calendar year. These points may be removed at the discretion of the Competition Secretary if the Clerk of Course of that event, fails to enter that class or category.

3.2 Points for determining SDCC Series Khanacross Outright Champion.

For each round of the SDCC KX Series, points will be awarded as follows:-

Position	1	2	3	4	5	6	7	8	9	10	11	12	13	14	15
Outright	60	55	51	48	46	45	44	43	42	41	40	39	38	37	36

Position	16	17	18	19	20	21	22	23	24	25	26	27	28	29	30
Outright	35	34	33	32	31	30	29	28	27	26	25	24	23	22	21

Position	31	32	33	34	35	36	37	38	39	40	41	42	43	44	45
Outright	20	19	18	17	16	15	14	13	12	11	10	9	8	7	6

Position	46	47	48	49	50	51	52	53	54	55	56	57	58	59	60
Outright	5	4	3	2	1	1	1	1	1	1	1	1	1	1	1

60, 55, 51, 48, 46, 45, 44, 43, 42, 41, 40, 39, 38, 37, 36, 35,34, 33,32, 31, 30, 29, 28, 27, 26, 25, 24, 23, 22, 21,20, 19,18,17,16,15,14,13,12,11,10,9,8,7,6,,4,3,2, for first O/R, 59 for 2nd O/R and so on, until 49th position. 1 point will be awarded to 50th and onwards.

The Outright points for each round will be added together to form the Outright Championship season points tally.

3.3 Points for determining SDCC Series Khanacross Class or Category Champion.

For each round of the SDCC KX Series, points will be awarded in each class and category as follows:-

Position	1	2	3	4	5	6	7	8	9	10
Class	30	25	21	18	16	15	14	13	12	11

Position	11	12	13	14	15	16	17	18	19	20
Class	10	9	8	7	6	5	4	3	2	1

For position 21 onwards, each will receive 1 point

(vehicle class & category J, J16 & L). Again, discounting non-SDCC eligible entrants.

Refer above for Junior(s) and Ladies Category points.

3.4 Handicap System applicable for SDCC Series rounds

Any vehicle fitted with tyres that would see them qualify for the Modified class

- Rally tyres
- Tyres marked 'not for highway use' or 'for competition use only'
- AT & MT type
- Tyres of an aggressive nature (as determined by the chief scrutineer)
- 'Mud & snow' or
- Tyres that have undergone tread modification

Will see them attract a handicap to their event Total elapsed (non-Penalty) time.

- **Any 2WD vehicles with the above types of tyres will attract a 2% handicap (penalty)**
- **4WD vehicles that qualify for class F will attract a 3% handicap (ie road tyres)**
- **4WD vehicles that qualify for class FM will attract a 5% handicap (with or without rally tyres)**

The handicap value applied will be the penalty time of the fastest in that group (not each individual's time)

3.5 Replacement Vehicles in Khanacross events (for the purpose of award and points eligibility)

If an entrant is unable to continue in their own vehicle and wishes, at the approval of the Clerk of Course and Chief Scrutineer, to change vehicles, it is recommended that they select a vehicle that would be eligible for the same class.

If the entrant changes vehicle class, it will make them ineligible for awards (trophies) and points for both/all classes. It is recommended that the entrant considers if registering a DNS for the remainder of the event, would be better for their class result. As a reminder, competitors are required to complete no less than 50% of the **runs** to be classified as a finisher.

If the entrant does change vehicle class, they are still eligible for outright awards (trophies) and points.

3.6 Dropping a Round

In both the Outright and Class points tally, entrants are to drop their lowest points scoring round (whether that be entered or not entered).

3.7 Tie Breaker rule

The Khanacross Club Series Champion and Class Series Champions will not be determined by tie breaker in the event of a tie. Both (or all) winners will be classified and joint winners of the title and trophy.

4. SDCC Khanacross Rules

4.1 VEHICLE REQUIREMENTS

1. All Vehicles must comply with Motorsport Australia 4K and Schedule A of the current Motorsport Australia Manual of Motor Sport.
2. Vehicles must be adequately muffled to comply with noise restrictions.
3. Particular attention will be to:-
 - a. General occupant safety
 - b. Steering
 - c. Brake system
 - d. Seat belt/safety harness
 - e. Seat/s
 - f. Wheels/tyres
 - g. Security of objects in the cabin.
4. The Chief Scrutineer shall rule on the acceptability of any vehicle to compete in the Event. This will apply to vehicles fitted with non-compliant roll cages
5. All vehicles must have an approved and correctly mounted and fire extinguisher of at least 900g capacity, and effective mud flaps fitted to drive wheels.
6. A Driver whose vehicle has broken down may use a replacement vehicle, provided the consent of the Clerk of the Course has been obtained. The replacement vehicle must be scrutineered before being allowed to compete and be used for the remainder of the competition.
7. Firewalls into the cabin of the vehicle need to be suitably sealed.

4.2 APPAREL

1. A minimum of a lap sash must be worn correctly at all times of competition complying with Schedule I of the current Motorsport Australia Manual of Motorsport.
2. All Drivers must wear approved footwear whilst competing. Refer Schedule D of the current Motorsport Australia Manual of Motorsport.
3. Approved helmets must be worn whilst competing. Refer Schedule D of the current Motorsport Australia Manual of Motorsport.
4. Approved helmet with visor or goggles must be worn in closed cars which have the windscreen removed. Refer Schedule D of the current Motorsport Australia Manual of Motorsport.
5. For all vehicles minimum clothing is "Neck to ankle to wrist" covering. Refer Schedule D of the current Motorsport Australia Manual of Motorsport.

4.3 CLASSES & CATEGORIES

1. Classes

- A – Production Vehicle 0 – 1500cc
- B – Production Vehicle 1501 – 2000cc
- C – Production Vehicle 2001 – 3000cc
- D – Production Vehicle over 3000cc
- E – Production Vehicle Rear Wheel Drive any capacity
- F – 4WD & AWD Production Vehicle
- AM – MODIFIED Production Vehicle or RALLY TYRES 0 -1500cc
- BM – MODIFIED Production Vehicle or RALLY TYRES 1501 -2000cc
- CM– MODIFIED Production Vehicle or RALLY TYRES 2001 – 3000cc
- DM – MODIFIED Production Vehicle or RALLY TYRES over 3000cc
- EM - MODIFIED Production Vehicle or RALLY TYRES Rear Wheel Drive any capacity
- FM – MODIFIED 4WD & AWD Production Vehicle
- S – 2WD Specials

NOTE:-

A Rear wheel drive vehicle must be nominated in EITHER appropriate engine capacity class OR Rear wheel drive class, it cannot be in both.

2. Categories

- J – JUNIORS under 16 years
- J16 – JUNIORS 16 to 17 years (inclusive)
- L – LADIES (Ladies may opt out of competing for this trophy)

4.4 PRODUCTION VEHICLE REQUIREMENTS

The following must apply for Production Vehicle classes

- A – Production Vehicle 0 – 1500cc
- B – Production Vehicle 1501cc – 2000cc
- C – Production Vehicle 2001cc – 3000cc
- D – Production Vehicle over 3000cc
- E – Production Vehicle Rear Wheel Drive any capacity
- F – 4WD & AWD Production Vehicle

NOTE:-

A Rear wheel drive vehicle must be nominated in EITHER appropriate engine capacity class OR Rear wheel drive class (E), it cannot be in both.

A Production Vehicle is a road going vehicle, which may be two wheel or four-wheel drive that has been produced by a manufacturer and sold to the general public through a recognised dealer network. A Production Vehicle may only be modified in accordance with the following conditions:

- a. A vehicle may not be converted from FWD to RWD or 2WD to 4WD or vice versa.
- b. The original bodyshell and the original bodywork panels must be retained. The overall length and silhouette, when viewed from the side and from above, must not be less than the original except where a modification permitted affects the silhouette.
- c. Each front door must remain operational with the original hinges and latch mechanism.
- d. A bumper bar which is affixed by fasteners, and is independent to and not integrated with any other bodywork, such as front air dam, front guards and grill, may be removed.

- e. Spoilers, air dams and wheel arch flares may be added or removed to the exclusion of being covered.
- f. Both driver and passenger front seats must remain in their standard position. It is permissible to remove the rear seats if required.
 - i. Driver's seat may be replaced with a racing seat but must have a harness type seatbelt fitted
 - ii. Front passenger seat must remain but if replaced with a racing seat must have a harness type seatbelt fitted
 - iii. Rear seat may be removed however integrity of rear fire wall must remain
 - iv. Fuel system must not be exposed inside the cabin
- g. Front door trims must be fitted, which may be of an alternate rigid material. Other interior trim or carpet etc. may be removed.
- h. Front headlights and rear taillights must remain in their standard location, although they do not need to function.
- i. The handbrake may be modified, but must be functional.
- j. The original windscreen must be retained. Each other window may be replaced with an alternate polycarbonate material and fixed in place. Each replacement front side window must be removable without tools.
- k. The engine and gearbox must be from the same manufacturer and have been available as an option in the model run of the vehicle.
- l. Engine/transmission cooling systems are free provided they are:
 - i. contained within the bodywork and may be fitted underneath the floorpan;
 - ii. not fitted in the cockpit; and
 - iii. fitted only with localised modifications by the removal of or replacement of material, such as engine radiator support panel, to facilitate a cooling system modification.
 - iv. Fuel system must not be exposed inside the cabin
- m. All turbocharged vehicles must have the intercooler in the original position
- n. Suspension and steering components may be replaced with free components with the following conditions:
 - i. Each component must maintain the principle and operation as per the original manufacturer's components.
 - ii. The mounting points on the bodywork or chassis for each suspension and steering component must remain as standard.
 - iii. Adjustment capabilities may be incorporated into replacement suspension or steering components. (i.e. adjustable spring platform on Macpherson Strut or coil over, adjustment in a lower control arm).
- o. Upgrading of brake rotors and pads is permitted.
- p. All wheels shall be fitted with tyres which are:
 - i. pneumatic, containing gas only,
 - ii. in a safe condition, and
 - iii. not fitted with any anti-skid attachments such as studs, chains etc.
- q. Wheels and tyres must fit inside the guard (silhouette)
- r. May not use any Rally tyre or tyres marked "not for highway use" or "for competition use only".
- s. Commercially available light vehicle tyres, including those marked LT or C will be allowed provided these tyres are appropriately speed rated and the tread pattern is of a road pattern, not a winter tread or mud and snow pattern.

SUV tyres defined as HT are allowed but not AT or MT or of any other aggressive nature. No modification of tread pattern
Failure to comply with the above items may result in the entry being placed in Modified Classes, excluded from results or excluded from competition

4.5 MODIFIED VEHICLE REQUIREMENTS

The following must apply for Modified Production Vehicle classes

- AM – MODIFIED Production Vehicle or RALLY TYRES 0 -1500cc
- BM – MODIFIED Production Vehicle or RALLY TYRES 1501 -2000cc
- CM– MODIFIED Production Vehicle or RALLY TYRES 2001 – 3000cc
- DM – MODIFIED Production Vehicle or RALLY TYRES over 3000cc
- EM - MODIFIED Production Vehicle or RALLY TYRES Rear Wheel Drive any capacity
- FM – MODIFIED 4WD & AWD Production Vehicle

NOTE:-

A Rear wheel drive vehicle must be nominated in EITHER appropriate engine capacity class OR Rear wheel drive class (EM), it cannot be in both.

4.5.1 A Modified Production Vehicle (Classes AM, BM, CM, DM, EM, FM) is a vehicle that has been modified beyond the criteria and requirements of a Production Vehicle.

The modifications permitted for a Production Vehicle are permitted for a Class AM, BM, CM, DM, EM, FM vehicle. Additionally a Class AM, BM, CM, DM, EM, FM vehicle must meet the following requirements:

- a. All parts of the original body between and including the front firewall and rear most rear suspension mounting points must remain intact including roof, pillars, and floor pan.
- b. Bodywork panels may be of a different material to the production part, except for the front doors which must comply with the Production Vehicle requirements, refer Production Vehicle 4.4(c).
- c. Any exposed metal brackets or bodywork components (chassis rails, bumper mounts etc.) which extended beyond the external bodywork remaining, be it modified or otherwise, or which may pose a hazard, to person or other objects, must be removed or covered with a suitable ridged material.

4.5.2 Permitted Modifications

The following modifications are permitted for a Class AM, BM, CM, DM, EM, FM vehicle beyond those permitted for a Production Vehicle:

- a. Rear doors, boot panel, tailgate/hatch may be modified leaving only the outer skin permanently and securely affixed in place.
- b. The bonnet or engine cover may be modified or replaced with an alternate solid material. All exposed rotating parts on the engine are to be fitted with a suitable guard to prevent contact by persons or other objects.
- c. Front and rear bumper bars, included those integrated to other bodywork, may be removed in their entirety.
- d. It is permitted to remove the windscreen in which case the vehicle must be fitted with a minimum of a Type 2 Safety Cage Structure complying with Motorsport Australia Manual; Schedule J.
- e. Each other window may be removed in its entirety however window nets or similar must be used.
- f. The engine and driveline are free in which case the following will apply:
 - i. The floor pan and firewall may be modified to accommodate the replacement or relocation of engine or driveline components. Any material removed from the floor pan or firewall must be replaced with material of the same type and fixed in place.
 - ii. The original chassis may be modified by the removal or replacement of material. Additional brackets/mounts may be added. In each case the integrity of the chassis must be maintained. ('Integrity' is meant to mean 'strength' not 'of original design')
- g. Each engine and driveline component must be suitably sealed from the cockpit.
- h. Suspension and steering components may be modified by the removal of or by the addition of material including the mounting points on the bodywork, chassis. Suspension and steering components are otherwise free.
- i. Brake components are free.
- j. Wheels and tyres must fit inside the guard (silhouette – from above & side on).
- k. May use any Rally tyre or tyres marked “not for highway use” or “for competition use only”. SUV tyres defined as HT, AT MT are allowed. However agricultural, bar and lug type tyres are not permitted.
- l. If using full harness belts you may remove dash crash pad, with no sharp edges to be exposed.

4.6 CRITERIA FOR 2WD SPECIALS:

Purpose-built vehicles, which must:-

- a. have a wheel base not less than 1800mm;
- b. be of sound and solid construction;
- c. be fitted with some form of protection between the engine and driver's compartment suitable and sufficient to prevent the passage of flame;
- d. be fitted with a solid and rigidly attached floor, and covers of solid material which effectively separate the passenger compartment from the exhaust system, the transmission shaft/s and joints, the brakes, the road wheels and their attachments and linkages;
- e. have sides on the passenger compartment extending at least from the toe-board to the rear of the seat/s, contiguous with the floor throughout their length, of a height not less than 150mm above all parts of the uncompressed seat cushion/s;
- f. be fitted with a securely attached driver's seat;
- g. be fitted with a fuel tank safely and securely installed;
- h. have any battery safely and securely installed;
- i. have all brake, fuel and electrical lines securely mounted;
- j. not have any open carburettor intake/s intruding into the passenger compartment. The use of flame-retardant air cleaner/s is recommended;
- k. have mudguards (if fitted) securely mounted;
- l. not have any form of electronically-controlled traction, braking or suspension control aids.

4.7 SAFETY CAGE STRUCTURE

- a. Specials must be fitted with a Safety Cage Structure complying with Schedule J of the Motorsport Australia Manual and the following:
- b. The minimum requirement is for a Type 2 Safety Cage Structure.
- c. A minimum of 50mm clearance is to be maintained above the driver's helmet (for all drivers of the vehicle) when measured perpendicular to a line drawn from the top of the main roll bar to the top of the engine (not including peripherals such as carburettors) or alternatively, the chassis at the front of the vehicle. Refer Diagram 1.
- d. The Safety Cage Structure must be mounted to the vehicle in accordance with Article 18 of Schedule J.
- e. It is highly recommended that vehicles be equipped (for each occupant) with safety nets or wrist/arm restraints, each properly attached, which ensure that each occupant cannot project beyond the line of the bodywork of the vehicle.

DIAGRAM 1.

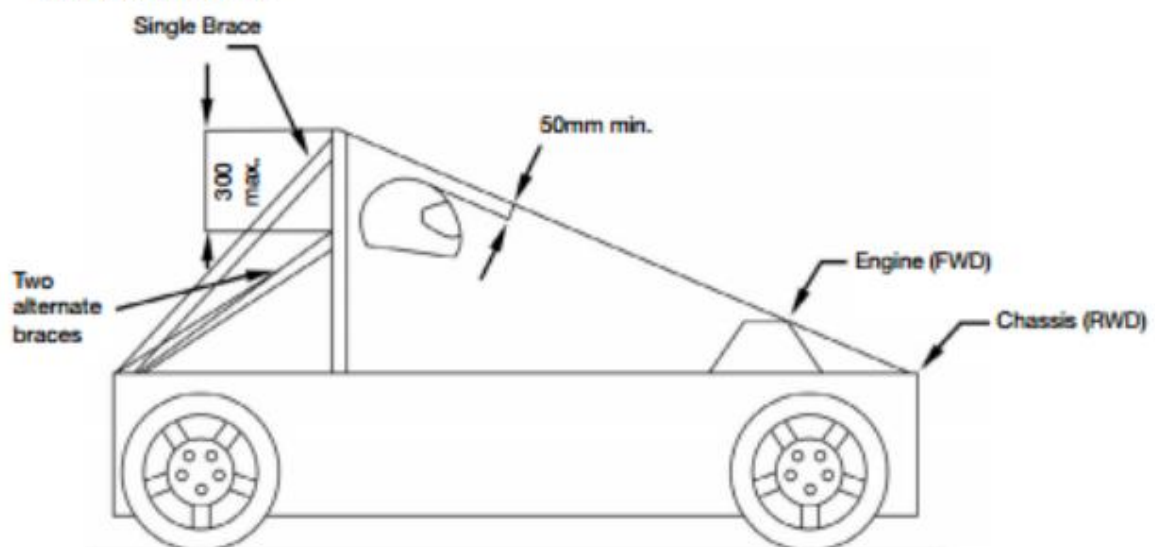

4.8 MINI MOKES (or similar open top vehicles)

Mini Mokes (or similar) must be fitted with a Safety Cage Structure which complies as a Type 2 in accordance with Schedule J of the Motorsport Australia Manual.

5. 2022 Membership Types, Prices and Entitlements

Full Membership

- Single
 - Adult \$ 70
 - Life \$ 0
 - Complimentary \$ 0
- Junior/JDP (12-17yrs) \$ 35
(Junior Membership can be obtained if the junior is under 18 at the time of renewing or taking up Membership, even if the person turns 18 during that competition year)
- Family - comprising of a maximum of 2 full single (Adult, Life or Complimentary) and no limit of juniors/children \$ 90

Other Memberships

- Associate \$ 20
- Club Registration (non-voting & non-competition) \$ 50
- Honorary (non-voting) \$ 0
- Day Membership (non-voting) \$ 30

Club Reg Log Book Allocation & First inspection

\$ 5

JDP Vehicle Hire

\$ 65

Entitlements

Type	GM Voting Rights	Motorsport Australia competition	Score Club Points	Club Reg eligible	Office Bearer	Event discounts	Magazine	Member Discounts
Adult	Y	Y	Y	Y	Y	Y	Y	Y
Life #2	Y	Y	Y	Y	Y	Y	Y	Y
Complimentary	Y	Y	Y	Y	Y	Y	Y	Y
Junior/JDP	N	Y	Y	N	Y	Y	Y	Y
Associate	Y	N	#1	N	Y	N	Y	Y
Club Registration	N	N	N	Y	N	N	Y	Y
Honorary	N	N	N	N	N	N	Y	Y
Children (u/12)	N	N	N	N	N	N	N	Y
Day	N	Y	N	N	N	Y	N	N

#1 – Associate Members may score club points in non-competition events (eg Economy Run), or Points for recognised tasks as a volunteer official, but NOT as a competitor in competition events.
 #2 – The vote for a Life Member who has deceased is not transferrable to another person, nor are they counted for purposes for determining a 'quorum'

Memberships that become active after November the 1st will carry across until the end of the following calendar year

6. Sub Committee establishment/dissolution

Other than our permanent MMM Park Sub-committee, there are currently no active sub committees